

VRML VISUALIZATION OF PELAGIC FISH MOVEMENT IN THE ECHOSOUNDER BEAM

MAREK MOSZYŃSKI, KRZYSZTOF BIKONIS, JERZY DEMKOWICZ

Technical University Of Gdansk
Narutowicza 11/12, 80 – 952 Gdansk, Poland
marmo@pg.gda.pl, binio@eti.pg.gda.pl

During over thirty years of development of echosounders, the acquisition software has developed different kind of charts for data visualization. In the paper the concept of creation of dynamic echograms from the data acquired in acoustical surveys is presented. As the modern split-beam echosounders allow for nonambiguous localization of targets in the water column, it is possible to visualize them in 3D coordinate system.

Virtual Reality Modeling Language VRML is a popular language used in modeling of virtual reality. Using its build-in properties, it is relatively easy to visualize movement of fish treated as an object in any coordinate system. VRML despite the typical application in computer graphics is also used in other various fields. For instance in chemistry it is used for visualization of atom particles, in medicine for modeling of human organs, in astronomy for visualization of trajectories of the stars and in geography and navigation for creation of 3D maps. Hence, in this paper we describe its application in fisheries. Additionally, as the any WWW browser can be equipped with VRML plugin 3D fish visualization can be redistributed in the Internet.

INTRODUCTION

Precise and advanced systems for acquisition and postprocessing of the hydroacoustic fishing survey data have been extensively used for the past three decades. The most popular echosounders are often supported by dedicated software used for data storage as well as for its analyzies, processing and visualization. Because of the large amount of data, its visualization is performed with 2D graphic technique e.g. with the visualization standards of type A and M [7] on an oscilloscope or a color computer screen. Such visualization, used mostly for echo analysis is usually supported which a color echogram, which displays echo sequences in successive transmissions. Both kinds of visualization have a common domain (time domain) in meter resolution. This type of visualization is typically used in all kinds of echosounders. Newer systems, used for searching pelagic fish and estimating their target strength, are

equipped with two transducers i.e. dual-beam systems or four transducers called split-beam echosounders. The split-beam method uses a special configuration of the echosounder's transducer. The transducer is split into four sectors (quadrants), which in the transmitting phase are impel parallel with the same amplitude and phase, forming together one full beam [6]. In the receiving mode, an echo signal reflected from the singular target is received by each sector separately. Then two pairs of segments, which are in perpendicular plains (parallel and perpendicular to a ship axis), do a compartment of echo phases shown in the Fig. 1.

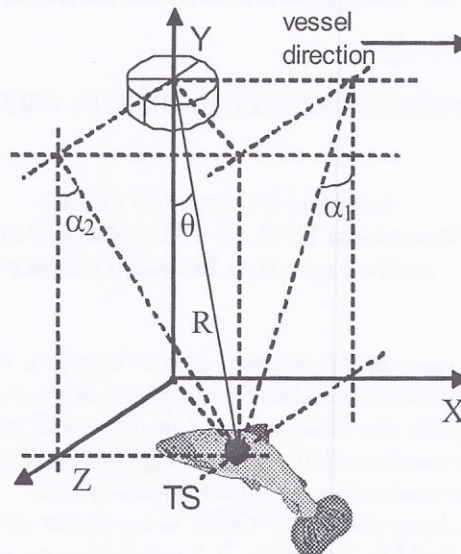

Figure 1. Echosounder data acquisition schema in Cartesian coordinate system

The target's location in the Cartesian coordinate system is received by a simple transformation of the sphere coordinates [6]:

$$\begin{cases} y = R \cdot \cos \theta \\ x = y \cdot \tan \alpha_1 \\ z = y \cdot \tan \alpha_2 \end{cases} \quad (1)$$

where $\theta = \arctan \sqrt{\tan^2 \alpha_1 + \tan^2 \alpha_2}$, R is the distance from the target and angles α_1 and α_2 are displayed in the Fig. 1. The split-beam system guarantees the accurate target localization and by adding GPS data it is possible to achieve geographical coordinates every detected object in every transmission. The split-beam method was worked out and applied in EY echosounder by the Norwegian company SIMRAD [6]. An example of a typical visualization of the split-beam echosounder output is shown in Fig. 2. It shows the target position versus the angle (*bull's-eye*); such visualization is available only for a split-beam system.



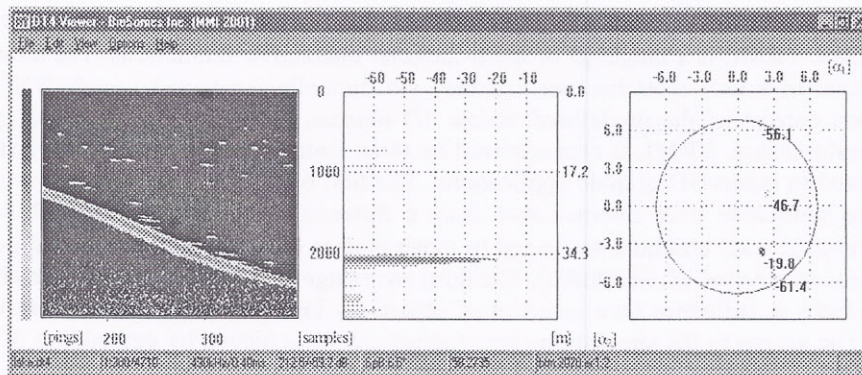

Figure 2. Data visualization from DTX Biosonics Inc. system

1. HYDROACOUSTIC DATA PROCESSING

Hydroacoustic data processing for three-dimensional visualization show in Fig. 3. The data, as records of envelope samples of the successive echosounder transmissions, are analyzed and recorded as a separate echo of a fish. Then a match is made between the echo and echoes from the further transmissions. A single moving fish in a beam gives a single echo (*fish tracking*). The algorithm requires a precise detecting algorithm, which introduces limits in a counting fish algorithm. The data enriched with the angle data of the split-beam can be transformed to the relative Cartesian coordinates and then transformed to the absolute Cartesian coordinates, after matching them with the current geographical coordinates. The data are put through a process then, which converts them to be complied with the VRML standard.

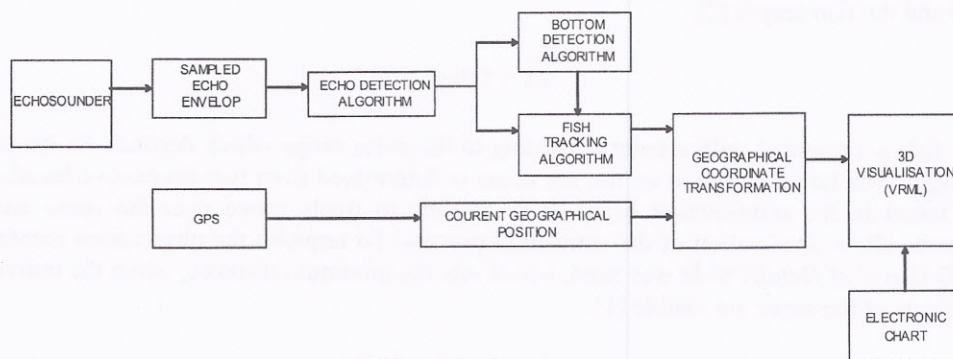

Figure 3. Hydroacoustic data processing

2. VRML ADVANTAGES

The Virtual Reality Modeling Language (VRML) was found in 1994, when the WWW enrichment by virtual reality was discussed during *WWW Convention in Geneva*. As a current standard version, we consider now VRML 97 (VRML 2.0), which was announced the international standard by ISO (International Standard Organization) in December 1997. VRML was developed in a natural process as the Internet evolved, moving from the text to



the WWW era. This evolution was inspired by a demand of graphical presentation of the Internet data. VRML is a language of multi-factorial interactive simulations. The simulations are provided to a user over Internet and they are mutually connected through WWW. The simulations consist of the predefined simple 3D objects, compounding of the complicated virtual world scenes. VRML is characterized by three features, which make it very attractive as compared to others 3D graphic applications. The first one is “an accessibility” – it allows to see the simulation over Internet even from a distance. The second is “a mobility” – it allows a user to walk around a scene and to move objects (it is not possible in traditional 3D applications like AutoCad, 3DStudio). The third advantage is “an interactivity”, which allows a user to have an influence on a behavior of objects by implementation of different kinds of sensors. The access to the simulation over Internet can be achieved by embedding of VRML file into HTML code.

3. DATA VISUALIZATION IN VRML

The VRML scene as a result of the measured data consists of following elements: a sea area model, a ship model with an echosounder, and a target model (fish). The model of the sea is made with the ELEVATIONGRID [1] node for a representation of the bottom and the BOX [1] node for a representation of the sea surface. The ship model was developed with the VRCreator 2.0 support using of elements included in the program resources. The fish was generated with INDEXFACESET [1] node, and the rear fin of the fish was implemented with a COORDINATEINTERPOLATOR [1] node. The input data for the fish description consists of: the target number (fish), the target echo start time [s], the target location in the echosounder beam in the 3D Cartesian coordinate system (x, y, z) [m], the target size, the target strength and the location of target in the yoz plane [rad]. The target echo time is based on its sample number and the sounder transmitting rate. The target is located according to the equation 1.1. and the target size l is based on empirical dependency between target strength (TS) and the fish length [2]:

$$\overline{TS} = 20 \log l - 29,2 \quad (2)$$

The fish is presented with a color according to the color range which depends on the target strength. The target direction on the yoz plane is determined from two successive location of the target in the echosounder beam. It is possible to freely move over the scene and its cameras allow observation of the simulation process. To improve the observation comfort, a LOD (*Level of Detail*) node was used, which sets the minimum distance, when the individual elements of the scene are visible [1].

4. SIMULATION

An example of dynamic visualization was developed from the actual data, collected during the acoustic survey on Lake Washington; the data were acquired by the digital echosounder DT6000 operated pings at 420kHz (these data are included with the DT system as an example). There are 4710 pings each having 2825 samples. Data processing module detected 8000 fish echoes and the number of fish extracted by fish tracking module was around 1000. As the data were collected with a rate of five pings per frequency, the acquisition time was about 17 minutes. In the scene description the time is kept by the simulation. Fig. 4 presents overview of the scene, and Fig. 5 presents a side of the beam. Fig. 6 is a top view and in the same time the profile of the beam is displayed.



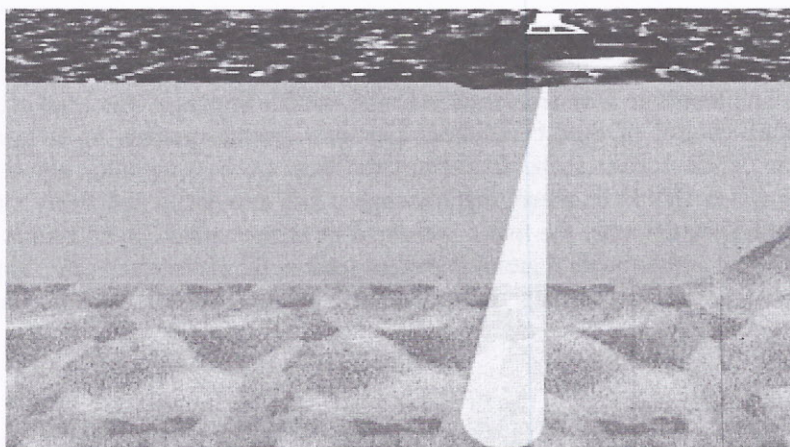

Figure 4. General view of the scene

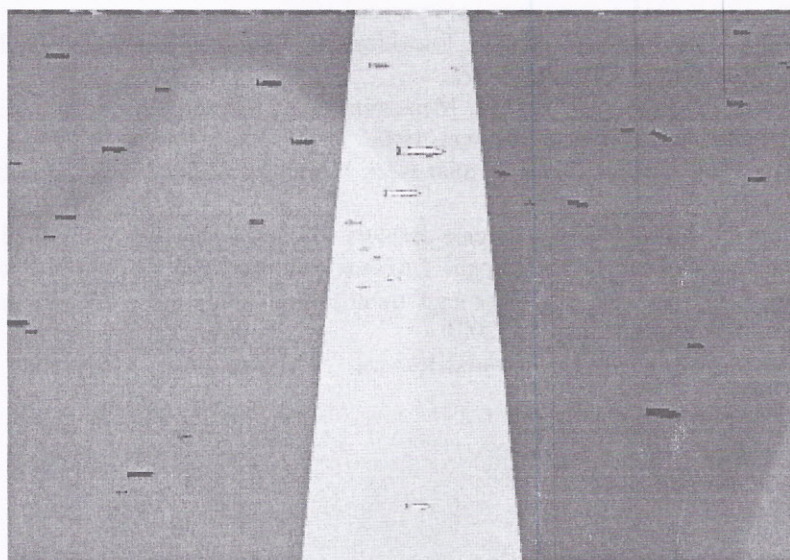

Figure 5. Side of the beam – three-dimensional equivalent of the echogram

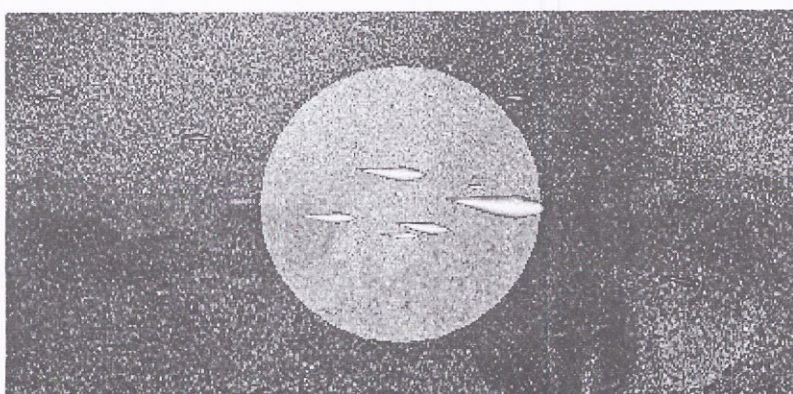

Figure 6. Top view – equivalent of the bulls-eye display



5. CONCLUSION

The software which converts the binary records from an acquisition system to the VRML scripting language was developed in C and Matlab language. The Matlab allowed for a simultaneous control of data correctness and their transformation. As it turned out an interpretation of the scene (scene rendering) requires much computing power for fluent display. It however should be noted, that although a user can easily and freely move around the entire virtual sea are, only the fishes registered by echosounder can be visible. Their size is estimated by an approximate regression pattern used in the fishery acoustic, and a move, a direction and an orientation is an approximated using interpolation based on the data from the echosounder.

REFERENCES

1. R. Carey, G. Bell, C. Marrin, ISO/IEC 14772 – 1:1997 The Virtual Reality Modeling Language. The VRML Consortium Incorporated 1997.
2. K. G. Foote, Target strength of fish, Encyklopedia Of Acoustics, Edited By Malcolm J. Crocker. John Wley & Sons, Inc. 1997.
3. K. G. Foote, A. Aglen, O. Nakken, Measurement of fish target strength with a split-beam echo sounder. J. Acoust. Soc. Am. 1986.
4. K. Dąbrowski, VRML97 Trzeci wymiar sieci. Warszawa: Zakład Nauczania Informatyki MIKOM 1998.
5. A. Stepnowski, M. Moszyński, Inverse problem solution techniques as applied to indirect in situ estimation of fish target strength. J. Acoust. Soc. Am. Vol. 107 (2554-25620) 2000.
6. A. Stepnowski, Systemy akustycznego monitoringu środowiska morskiego. Gdańsk: Gdańskie Towarzystwo Naukowe 2001.
7. A. Nowicki, Diagnostyka ultradźwiękowa, Wydawnictwo Medyczne MAKmed, Gdańsk 2000.