

Hocine TILIOUINE

GDAŃSK UNIVERSITY OF TECHNOLOGY, FACULTY OF ELECTRICAL AND CONTROL ENGINEERING, DEPARTMENT OF THEORETICAL ELECTROTECHNICS AND INFORMATICS

Transient stability improvement of turbogenerator using fuzzy control

Dr inż. Hocine TILIOUINE

He was born in Dellys, Algeria. He received the electrical engineering degree in 1977 from "Ecole Nationale Polytechnique d'Alger" and the Ph.D degree in 1986 from the "Gdańsk University of Technology" where he is presently working. His interests are in power system modelling and control and in artificial intelligence based techniques applied to excitation and governor control.

e-mail: tiliouin@ely.pg.gda.pl



Abstract

The paper develops an adaptive fuzzy control system for a turbogenerator. The control system consists of a voltage controller and a power system stabilizer. The parameters of the proposed control system were optimized using genetic algorithms and are updated on line to get an optimum performance of the power system. Simulation tests of the study power system due to three-phase short-circuit or small deviation of the infinite bus voltage is presented. Moreover, a comparison between the power system response using fuzzy control strategy and conventional control is obtained.

Streszczenie

W artykule umówiono model rozmytego i adaptacyjnego układu regulacji turbo-generatora. Model ten składa się z: regulatora napięcia i stabilizatora systemowego. Parametry proponowanego modelu układu regulacji zostały zoptymalizowane wykorzystując algorytm genetyczny i są dostrajane w czasie pracy turbozespołu w celu uzyskania optymalnego stanu pracy. Przedstawiono badania symulacyjnych przejętego układu jednomaszynowego przy trójfazowym zwarciu i małym zakłóceniu napięcia. Poza tym, porównano wyniki symulacji uzyskane z rozmytym i z klasycznym układem regulacji.

Keywords: fuzzy controller, fuzzy power system stabilizer (PSS), transient stability, turbogenerator

Słowa kluczowe: regulator rozmyty, rozmyty stabilizator systemowy, stabilność dynamiczna, turbogenerator

1. Introduction

Nowadays, power systems are operated more and more with reduced security margins. This situation makes power systems vulnerable to perturbations. One of the emerging problems, as a result of the heavy operation of the power systems, is the low frequency oscillations that can appear both under normal and disturbed conditions [1]. The oscillations have a negative effect on the power system flows and can result in instability of the system. Adaptive PSS have the capability to damp power system oscillations. This function is very attractive since modern power systems are expected to operate in interconnected mode. Furthermore, interconnections are often realized by weak tie lines, which are sensitive to power system oscillations.

The applying of self-tuning systems to overcome the above difficulties requires high complex mathematical tools, an exact mathematical model and precise data of the controlled process. The turbogenerator is highly nonlinear dynamic plant. Fuzzy logic set theory or neural networks are very suitable in the designing of control system for a such plant [2, 3, 4]. In this paper, the adaptive fuzzy excitation control is studied for transient stability and damping improvement. The fuzzification phase of the control system is defined. The simulation results of a sample system are presented. The improvement of the transient stability of the sample system is clearly demonstrated.

2. Simulated power system description

The power system used in the simulation consists of a synchronous machine connected to an infinite bus through transformer unit and transmission line, an exciter with a fuzzy controller and a fuzzy PSS, a condensing turbine and a speed turbine controller.

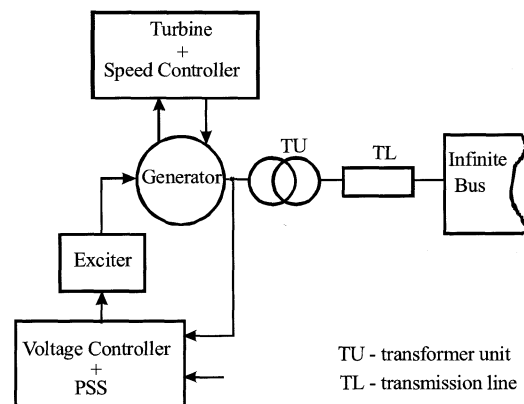

Fig. 1. Diagram of study system

Rys. 1. Schemat blokowy badanego układu

3. Fuzzy excitation control system

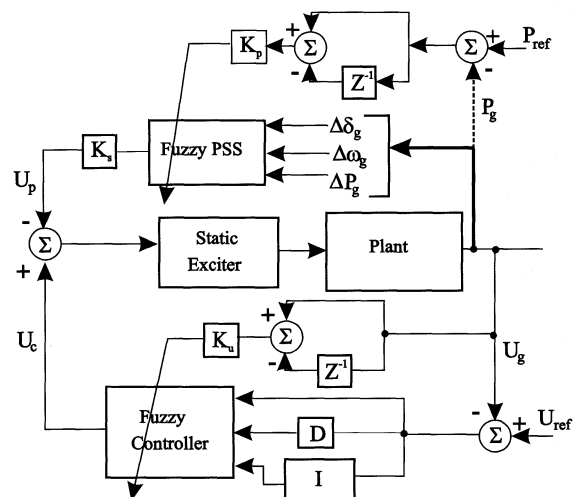

Fig. 2. Schematic diagram of the fuzzy control system

Rys. 2. Schemat blokowy rozmytego układu regulacji

Fig. 2 shows the block diagram of the proposed fuzzy control strategy. The selected control inputs are:

- the deviation generator voltage ΔU_g , its derivative $\frac{dU_g}{dt}$ and its integral $\int \Delta U_g dt$ for the controller;
- the deviations $\Delta P_g, \Delta\omega_g, \delta_g$ for the power system stabilizer. P_g, ω_g, δ_g are successively the active power, the angular speed and the power angle of the synchronous machine under study. In fig.3.1 and fig.3.2 are represented the fuzzy membership functions of the above control input variables.

Each input, as well as for the voltage controller and for the PSS,

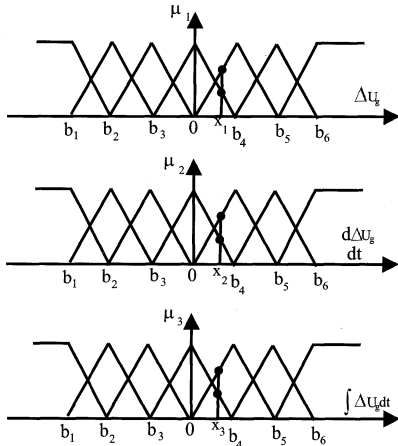

Fig. 3.1. Membership functions for the controller input variables
Rys. 3.1. Funkcje przynależności zmiennych wejściowych regulatora

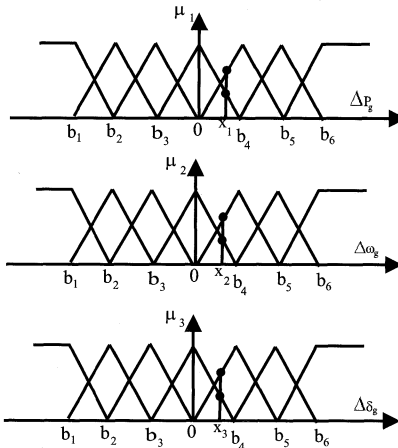

Fig. 3.2. Membership functions for the PSS input variables
Rys. 3.2. Funkcje przynależności zmiennych wejściowych stabilizatora systemowego

is quantified into seven linguistic values: **NL**-negative large, **N**-negative, **NS**-negative small, **ZE**-zero, **PS**-positive small, **P**-positive, **PL**-positive large.

The boundaries of the parts are designed by b_i ($i=1..6$). For each input signal value x_k ($k=1..3$), we have two nonzero membership degrees μ_{ij} with $i=1,2,3$ and $j=1,2$. To calculate the output signal for the controller or for the PSS, we use a very simple method avoiding the defuzzification strategy. Each product $\mu_{ik}\mu_{jl}$, of two membership degrees μ_{ik} and μ_{jl} belonging to two different input signals

$(\Delta U_g, \frac{dU_g}{dt})$, $(\Delta U_g, \int \Delta U_g dt)$, $(\frac{dU_g}{dt}, \int \Delta U_g dt)$ or $(\Delta P_g, \Delta \omega_g)$, $(\Delta P_g, \Delta \delta_g)$ and $(\Delta \omega_g, \Delta \delta_g)$ for the PSS, is multiplied by an appropriate crisp value λ_{kl} . The sum of the products gives the value of the output signal:

$$U_{c/p} = \sum_{i=1,2,3; j=2,3; i \neq j} \sum_{k=1,2; l=1,2} \lambda_{kl} \mu_{ik} \mu_{jl} \quad (1)$$

U_c - for the fuzzy controller; U_p - for the fuzzy PSS.

The crisp parameters λ_{kl} are updated on line using the deviation signal resulting from two consecutive (with sample time $T=10\text{ms}$) voltage values $U_g(k)$ and $U_g(k-1)$ for the controller and from $P_g(k)$ and $P_g(k-1)$ for the fuzzy PSS. All the parameters, b_i ($i=1..6$) shown in fig. 3.1 and fig. 3.2, and K_u , K_p and K_s shown in fig.2, were optimized during the designing-phase of the control system.

4. Simulation tests and results

Simulation study is carried out to investigate the validity of the proposed control strategy. The performance of the proposed control sys-

tem has been evaluated under different initial operating conditions and disturbances:

- in fig. 4.1a, fig. 4.1b the initial operating condition is the nominal set point $P_g=0.85$ [p.u] $Q_g=-0.527$ [p.u] and the disturbance -5% step change of the infinite bus voltage. Both controllers are without PSS. The fuzzy controller provides better oscillations damping than the conventional.
- in fig. 4.2a, fig. 4.2b and in fig. 4.3a, fig. 4.3b the initial operating condition is $P_g=0.85$ [p.u] $Q_g=0.2$ [p.u] (capacitive) and the disturbance a three-phase short-circuit below the transformer unit. The fault is cleared after 150 ms. In this case the fuzzy power system stabilizer gives a remarkable oscillations damping.

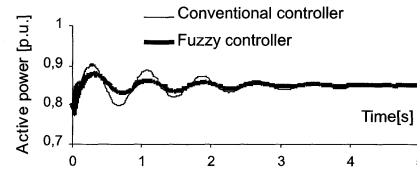

Fig. 4.1a. Active power response for a -5% step change of infinite bus voltage $P_g=0.85$ [pu], $Q_g=-0.527$ [p.u]. Both controllers without PSS

Rys. 4.1a. Przebieg mocy czynnej generatora po -5% skokowym wzroście napięcia systemu elektroenergetycznego. $P_g=0.85$, $Q_g=-0.527$. Oba regulatory bez stabilizatora systemowego

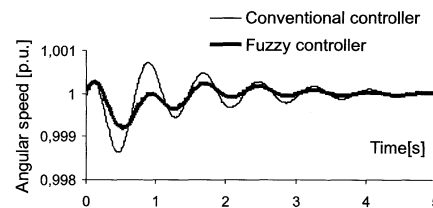

Fig. 4.1b. Angular speed response for a -5% step change of infinite bus voltage $P_g=0.85$ [pu], $Q_g=-0.527$ [p.u]. Both controllers without PSS

Rys. 4.1b. Przebieg prędkości obrotowej generatora po -5% skokowym wzroście napięcia systemu elektroenergetycznego. $P_g=0.85$, $Q_g=-0.527$. Oba regulatory bez PSS

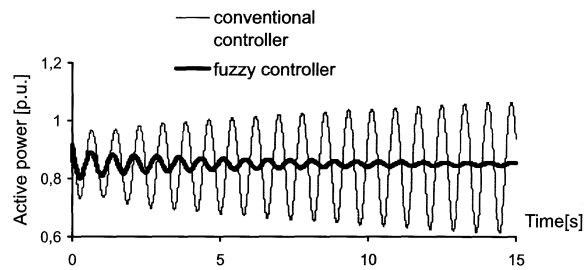

Fig. 4.2a. Active power response for a 5% step change of infinite bus voltage. $P_g=0.85$ [pu], $Q_g=0.2$ [p.u]. Both controllers without PSS

Rys. 4.2a. Przebieg mocy czynnej generatora po 5% skokowym wzroście napięcia systemu elektroenergetycznego. $P_g=0.85$, $Q_g=0.2$. Oba regulatory bez PSS

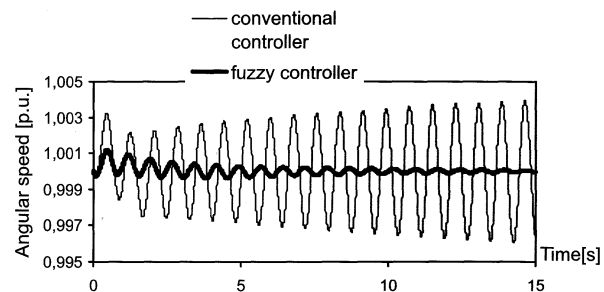

Fig. 4.2b. Angular speed response for a 5% step change of infinite bus voltage. $P_g=0.85$ [p.u.], $Q_g=0.2$ [p.u]. Both controllers without PSS

Rys. 4.2b. Przebieg prędkości obrotowej generatora po 5% skokowym wzroście napięcia systemu elektroenergetycznego. $P_g=0.85$, $Q_g=0.2$. Oba regulatory bez PSS

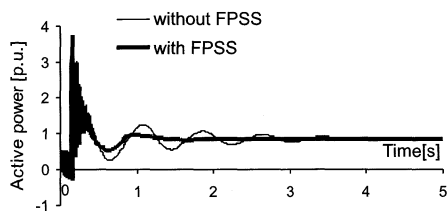

Fig. 4.3a. Active power response with fuzzy controller for a three-phase short-circuit. $P_g=0.85$ [p.u.], $Q_g=0.2$ [p.u.]

Rys. 4.3a. Przebieg mocy czynnej generatora z regulatorem rozmytym po trójfazowym zwarciu. $P_g=0.85$, $Q_g=0.2$

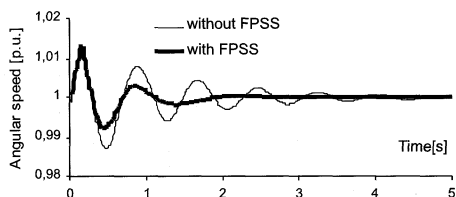

Fig. 4.3b. Angular speed response with fuzzy controller for a three-phase short-circuit. $P_g=0.85$ [p.u.], $Q_g=0.2$ [p.u.]

Rys. 4.3b. Przebieg prędkości obrotowej generatora z regulatorem rozmytym po trójfazowym zwarciu. $P_g=0.85$, $Q_g=0.2$

5. Conclusion

This paper presents an on-line fuzzy control scheme for a turbogenerator. The simulation results prove the robustness and reliability of the proposed fuzzy control strategy in terms of high performance of power system. It effectively improves the system transient stability and damping requirements.

References

- [1] J. Machowski, J. Bialek, J. R. Bumby: Power System Dynamics And Stability, John Wiley & Sons, Chichester, England 1997.
- [2] Hao Ying: Fuzzy Control and Modeling, Analytical Foundations and Applications, IEEE Press, New York 2000.
- [3] T. Hiyama, K. Miyazaki, H. Satoh: A Fuzzy Logic Excitation System for Stability Enhancement of Power Systems with Multi-mode Oscillations, IEEE Transactions on Energy Conversion, Vol. 11, No. 2, June 1996.
- [4] Z. Lubośny, H. Tiliouine: Composed Fuzzy Logic Controller for a Turbine Generator-Unit, Archiwum Energetyki, Nr 1-2, 1998.

Tytuł: Poprawa stabilności dynamicznej turbogeneratora z wykorzystaniem sterowania rozmytego

Artykuł recenzowany

*Dziękując za zaufanie i współpracę
Wszystkim naszym Partnerom i Kontrahentom
Życzymy dalszych sukcesów,
Udanych inwestycji i pomyślności
W nadchodzącym 2004 Roku.*

skamer
Automation Control Measurement

WESOŁYCH ŚWIĄT